



NorStone
design

Trio

This stylish video furniture will carry your electronic devices and TV sets or flat screen up to 176.3 lbs (80 kg).



Specifications

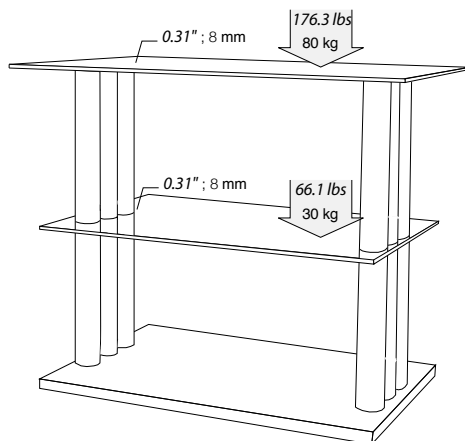

Structure: Powder coated steel and MDF.
Internal and top shelves: Tempered glass.
Bottom shelf: Light oak finish.

Maximum load: Top shelf can hold up to 176.3 lbs; 80 kg
Internal shelves can hold up to 66.1 lbs; 30 kg

Dimensions: Overall dimensions: W30.5" x D19.3" x H26.2"
W775 x D490 x H665 mm
Internal shelf: W21.6" x D16.9"
W550 x D430 mm
Top shelf: W30.5" x D16.3"
W775 x D490 mm
Height between shelves: a: 12.2"; 310 mm
b: 11.6"; 295 mm

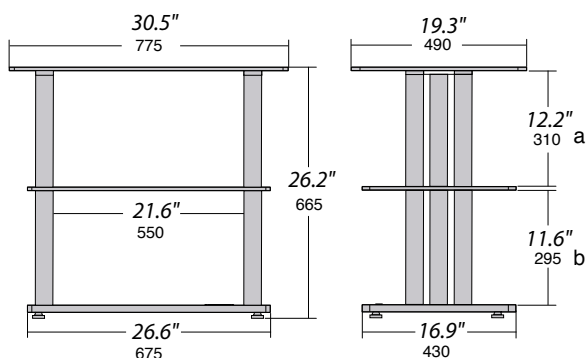

Packaging: Delivered in flat box.
Accessories: Screws kit, mounting instructions, mounting tools.

Brown packaging.
Packaging size: W34.6" x D21.6" x H5.5"
W880 x D550 x H140 mm
Gross weight: 61.7 lbs; 28 kg
Net weight: 56.4 lbs; 25,6 kg
Number of labels: 1 front and 1 back.

Details

On the same range:



Trio AV