



NorStone
design

Trio AV

This stylish video furniture will carry your electronic devices and TV sets or flat screen up to 176.3 lbs (80 kg).



Specifications

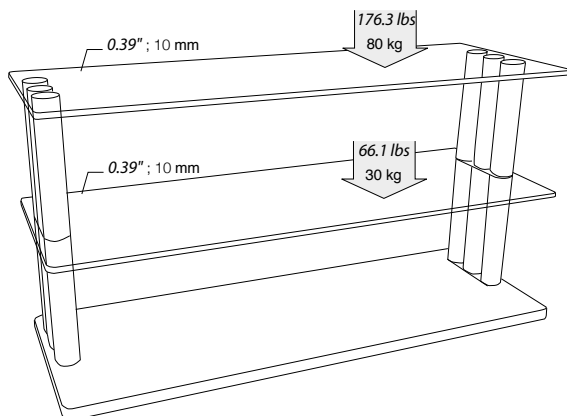

Structure: Powder coated steel and MDF.
Internal and top shelves: Tempered glass.
Bottom shelf: Light oak finish.

Maximum load: Top shelf can hold up to 176.3 lbs; 80 kg
Internal shelves can hold up to 66.1 lbs; 30 kg

Dimensions: Overall dimensions: W43.3" x D15.7" x H22.4"
W1100 x D400 x H570 mm
Internal shelf: W38.3" x D15.7"
W975 x D400 mm
Top shelf: W43.3" x D15.7"
W1100 x D400 mm
Height between shelves: a: 10.2"; 260 mm
b: 10.2"; 260 mm

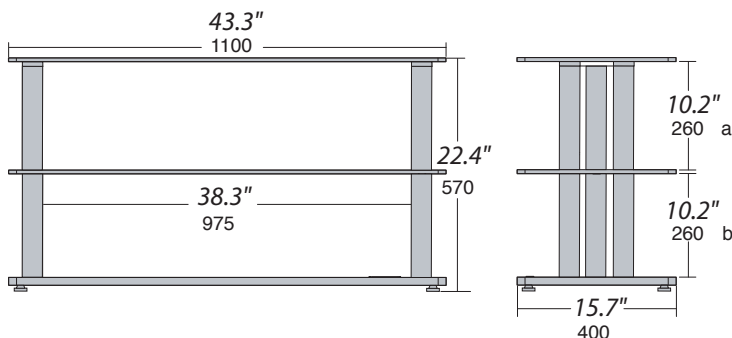

Packaging: Delivered in flat box.
Accessories: Screws kit, mounting instructions, mounting tools.

Brown packaging.
Packaging size: W47.6" x D19.1" x H5.9"
W1210 x D485 x H150 mm
Gross weight: 84.9 lbs; 38,5 kg
Net weight: 78.9 lbs; 35,8 kg
Number of labels: 1 front and 1 back.