



NorStone
design

Epsis 2

Largely inspired by the Scandinavian style, Epsis 2 is a strong and efficient Audio/Video furniture that provides space for up to 6 devices. The top shelf can also be used to carry a TV set, a plasma or a LCD TV up to 187.3 lbs (85 kg). The purity and simplicity of its shapes makes it easy to integrate.



Specifications

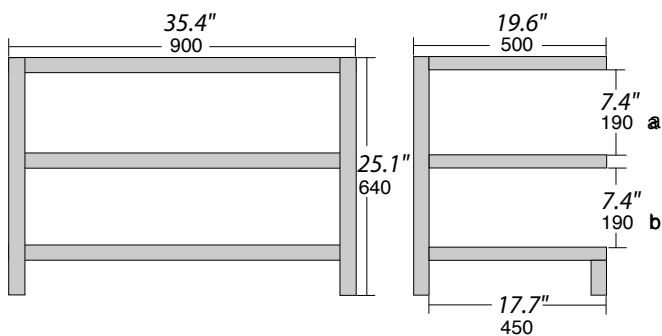
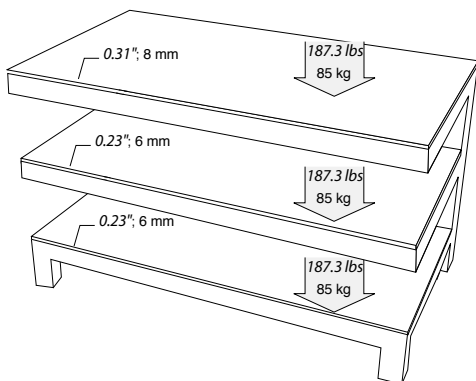

Structure: Powder coated steel.
Shelves: Tempered frosted glass.

Maximum load: Top shelf can hold up to 187.3 lbs; 85 kg
Internal shelves can hold up to 187.3 lbs; 85 kg

Dimensions: Overall dimensions: W35.4" x D19.6" x H25.1"
W900 x D500 x H640 mm
Internal shelves: W35.4" x D17.7"
W900 x D450 mm
Superior shelf: W35.4" x D19.6"
W900 x D500 mm
Height between shelves:
a: 7.4"; 190 mm
b: 7.4"; 190 mm

Packaging: Delivered in flat box.
Accessories : Screws kit, mounting instructions, mounting tools.

Brown packaging.
Packaging size: W38.6" x D24" x H6.3"
W980 x D610 x H160 mm
Gross weight: 78.3 lbs; 35,5 kg
Net weight: 72.7 lbs; 33 kg
Number of labels: 1 front and 1 back.

Details

Color: Powder coated steel

