

(x1)



(x2)



(x1)



(x10)

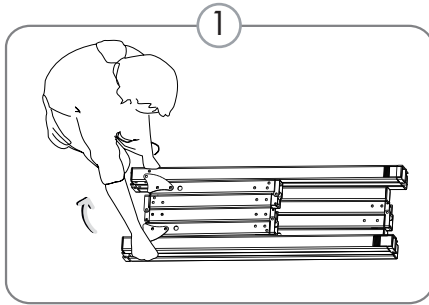

1

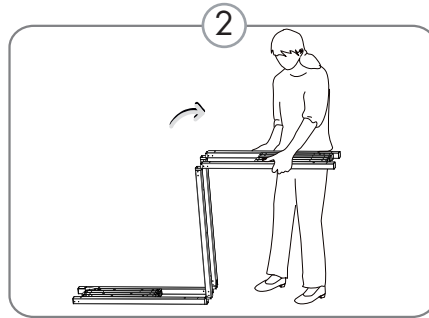

2

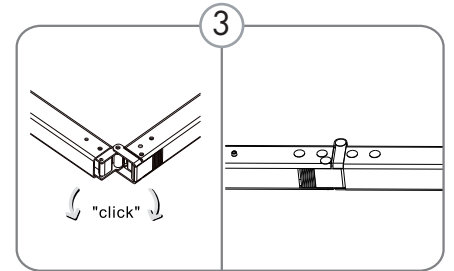

3

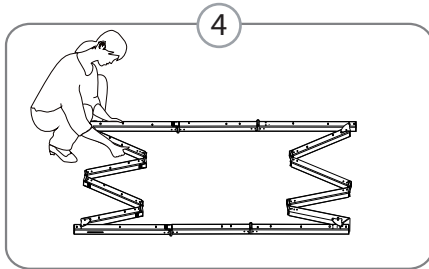

4

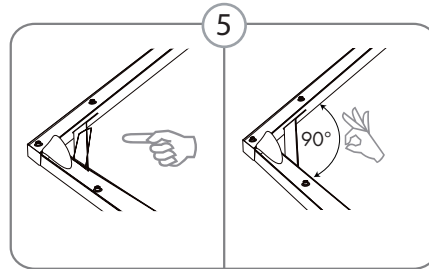

5

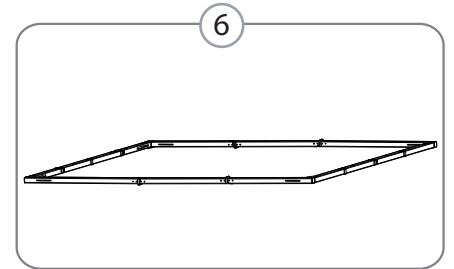

6

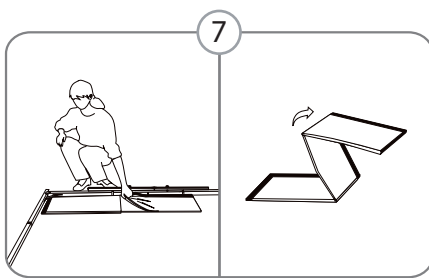

7

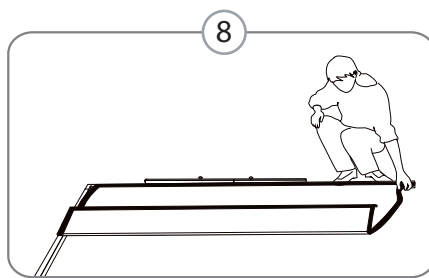

8

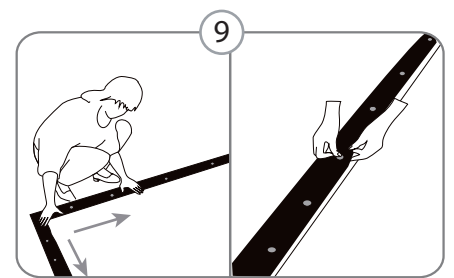

9

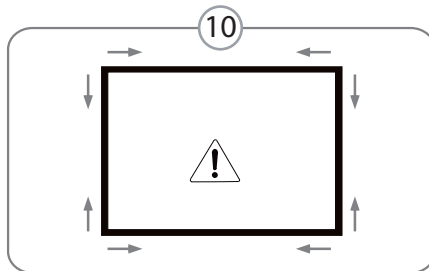

10

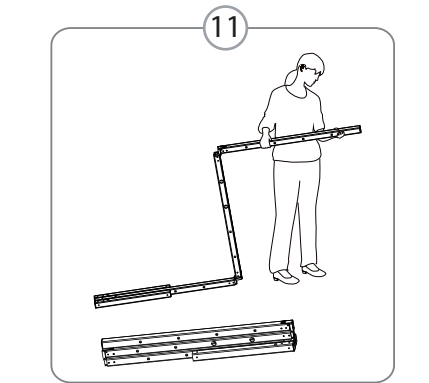

11

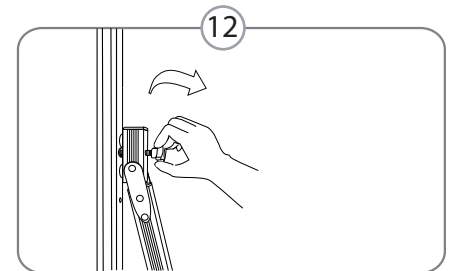

12

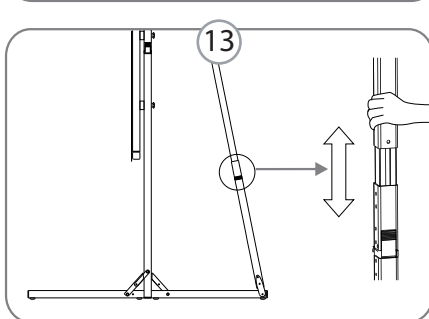

13

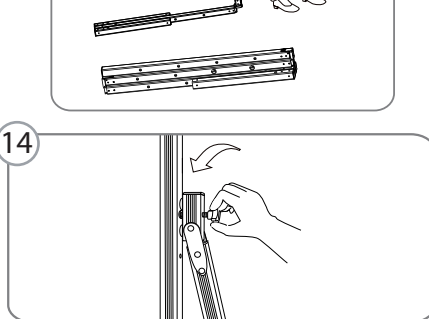

14

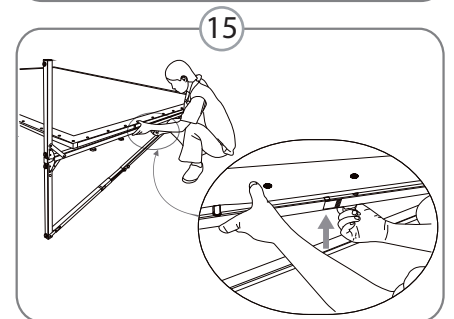

15

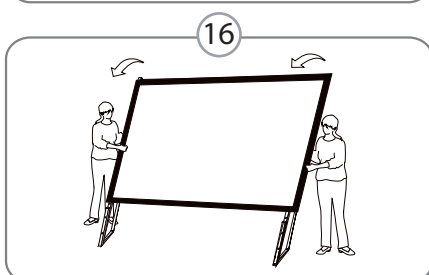

16

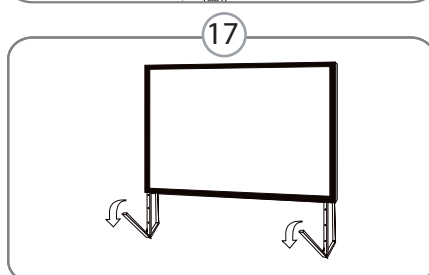

17

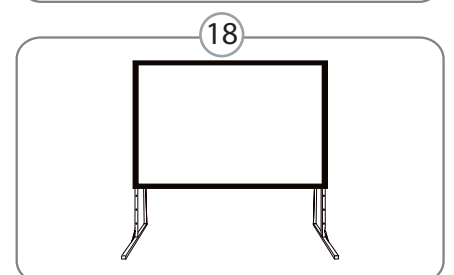

18

Congratulations and thank you for your choosing of a LUMENE projection screen.

This screen has been designed to offer a clear, bright and contrasted image.

It is also of a great reliability and very easy to use.

Important operating considerations:

Setting up is very easy but has to be done carefully to ensure its durability. Before first use, always position your screen is horizontally on a stable and level surface.

Warning:

- Do not hang or place anything on the screen when unfold.
- Unfold the screen on a clean and plane surface.
- Dust and scratches will lower the image of projection quality. Please pay particular attention to the following points:
 - a. Do not touch the screen surface with your hand.
 - b. Do not draw on the screen surface.
 - c. Do not cruff or scratch the screen with hard sharp items subject to cause damage.
 - d. Never use chemicals to wash the screen surface.
- Make sure there is nothing on the screen before fold it.
- To remove dust on the cloth, use a dry and soft-haired brush and rub it delicately.
- Close the screen to protect the cloth.

LIMITED WARRANTY:

All LUMENE products carry a two years limited warranty period when purchased from LUMENE, a LUMENE distributor or a LUMENE authorized retailer. This warranty covers all defects in materials and workmanship in the product manufactured by LUMENE.

Warranty limitation and exclusions:

This warranty covers only the products purchased from LUMENE or a LUMENE authorized retailer or distributor and runs for a two years period from the date of the purchase by the first end-user.

This limited warranty is subject to the following exceptions:

- The external case is damaged or deteriorated.
- The serial number has been removed, modified or made illegible.
- The defects or damage result from use of the products in a manner that is not normal or customary; improper operation or misuse; accident or neglect such as dropping the products onto hard surfaces; contact with water, rain, extreme humidity; contact with sand, dirt or the like; or contact with extreme heat, or spills of food or liquid.
- Physical damage to the surface of the product, including scratches, cracks or other damage.
- No respect of the instructions supplied with the product.
- Damage due to the shipment of the product (claims have to be addressed to the carrier).
- Someone other than LUMENE or its authorized service centers attempts to maintain, alter, modify or service the product in any way. Any of these voids the warranty.

To be eligible for limited warranty coverage:

The limited warranty applies only to the first end-user. Any person exercising a claim under this limited warranty must show the proof of the date of purchase, such as the sales receipt or invoice, and that the product was purchased new. The warranty is strictly limited to the country of the original purchase.

Warranty related expenses:

LUMENE will take charge of all the expenses on parts and labor related to the repair or the replacement of the products. The expenses related to the shipping and insurance fees will be shared as described below.

To obtain warranty service:

During the warranty period, to exercise the limited warranty, the purchaser must first contact:

- 1) The original place of purchase,
- 2) The LUMENE local distributor,
- 3) LUMENE.

You will receive instructions on how to ship the product to the nearest designated LUMENE authorized Service Center. The product must also be packed in its original packaging or a similar package insuring an equal degree of protection. You must ship it with freight, duties and insurance prepaid. Regardless of where you are instructed to return the product, you must always include:

- a) A copy of your invoice, bill of sale or other comparable proof of purchase.
- b) A written description of the problem.
- c) The name and location of the place of purchase and, most importantly,
- d) Your address and telephone number.

Always retain your original proof of purchase.

Do not send any product back to a service center before prior agreement.

Upon receipt of the product, LUMENE or its authorized service center will check the product and will ship you a repaired or replacement product, freight and insurance expenses prepaid. If additional information is required, please contact your retailer or the LUMENE local distributor.

Limitation of liability:

Except where these dispositions are inapplicable or unlauded to state laws or other jurisdiction rights:

For any defective product, LUMENE sole liability is to repair or replace the product.

By no means no event shall LUMENE be liable, whether in contract or tort (including negligence) for damages in excess of the purchase price of the product, or for any indirect, incidental, special or consequential damage of any kind or to any other products, or loss of revenue or profits, loss of business, or other financial loss arising out of or in connection with the ability or inability to use the product, to the full extent these damages may be disclaimed by law. Any litigation, which cannot be regulated by way of preliminary conciliation and relating to the interpretation or the execution of this Warranty and the obligations herein contained will be distinct definitively, according to the rules of conciliation and arbitration of the International Chamber of Commerce of Paris - France, by one or more referees named in accordance with its rules. The applicable law will be the French one.

